

Low Profile Off-Center Single-Point

FEATURES

- Capacities: 5 to 1000 kg
- Cost-effective load cell for scales of simple construction
- Anodized aluminum alloy
- NTEP Class III 5000S approval from 5 kg to 500 kg
- OIML C3 approval from 5 kg to 500 kg
- OIML C6 approval from 500 kg to 1000 kg
- Platform size: 16" x 24"/40 cm x 60 cm
- **Optional**
 - FM approval available

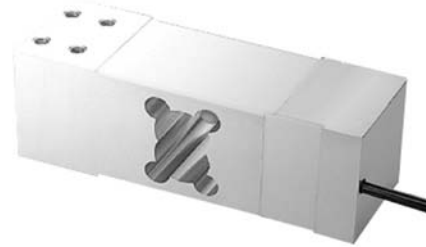

APPLICATIONS

- Platform scales (single load cell)
- Packaging machines
- Dosing/filling
- Belt scales/conveyor scales
- In-motion check weigher

DESCRIPTION

LOC is a low profile single-point load cell designed for platform scales and hanging scales. It is a cost-effective load cell for scales of simple construction.

LOC is constructed of anodized aluminum, and is environmentally sealed up to IP66 levels providing excellent protection against moisture and humidity.

OUTLINE DIMENSIONS in inches [millimeters]

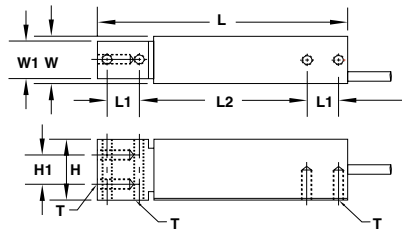

SE
5–150 kg
Cable Length: 3.3'/1m
Platform Size:
16"x16"/40 cm x 40 cm

Wiring diagram
+ Excitation Red
– Excitation Black
+ Signal Green
– Signal White

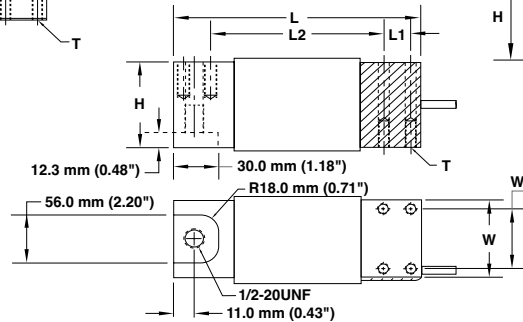

ME
50–800 kg
Cable Length: 6.7'/2m
Platform Size:
16" x 24"/40 cm x 60 cm

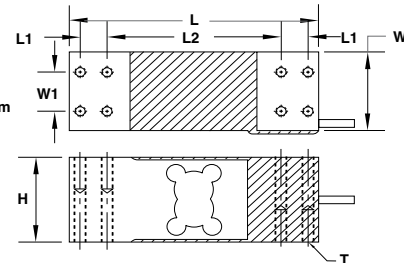

LE
100–1000 kg
Cable Length: 10'/3m
Platform Size:
16" x 24"/40 cm x 60 cm

CAPACITY (kg)			L	L ₁	L ₂	W	W ₁	H	H ₁	T
SE	5/7/10/15/20/30/50/60/75/100/150	mm	150.0	19.0	100.0	30.0	24.0	39.5	19.0	M6x1.0
		(inch)	5.91	0.75	3.94	1.18	0.94	1.56	0.75	1/4-20UNF
ME	50/100/150/250/300/500/635/800 45A/100A/150A/250A/300A/500A/635A	mm	174.0	19.0	122.0	60.0	30.0	65.0	–	M8 x 1.25
		(inch)	6.85	0.75	4.80	2.36	1.18	2.56	–	5/16-18UNC
LE	100/250/100A/150A/250A/300A/500A/ 635A/800A/1000A	mm	191.0	25.0	125.0	76.2	60.0	75.0	–	5/16-18UNC
		(inch)	7.52	0.98	4.92	3.00	2.36	2.95	–	

*A: American Standard Thread

Low Profile Off-Center Single-Point

SPECIFICATIONS					
PARAMETER	VALUE				UNIT
NTEP/OIML accuracy class	NTEP III	Non-Approved	C3	C6	
Maximum no. of intervals (n)	5000 single*	1000	3000**	6000***	
$Y = E_{max}/V_{min}$	8000	1400	10000	12000	Maximum available
Standard capacities (E_{max})	5, 7, 10, 15, 20, 30, 50, 60, 75, 100, 150, 250, 300, 500, 635, 800, 1000				kg
Rated output—R.O.	2.0				mV/V
Rated output tolerance	10				±% of rated output
Zero balance	1				±% of rated output
Non-linearity	0.020	0.025	0.020	0.015	±% of rated output
Hysteresis	0.020	0.025	0.020	0.015	±% of rated output
Non-repeatability	0.020				±% of rated output
Creep error (20 minutes)	0.025	0.030	0.020	0.015	±% of rated output
Zero return (20 minutes)	0.025	0.030	0.020	0.015	±% of rated output
Temperature effect on min. dead load output	0.0022	0.0026	0.0014	0.0012	±% of rated output/°C
Temperature effect on sensitivity	0.0010	0.0015	0.008	0.008	±% of applied output/°C
Compensated temperature range	-10 to +40				°C
Operating temperature range	-20 to +60				°C
Safe overload	150				% of R.C.
Ultimate overload	200				% of R.C.
Excitation, recommended	10				VDC or VAC RMS
Excitation, maximum	15				VDC or VAC RMS
Input impedance	410±10				Ω
Output impedance	350±3				Ω
Insulation resistance	>5000				MΩ
Construction	Anodized aluminum				
Environmental protection	IP66				

* Capacities 5–500 kg

** Capacities 5–500 kg

*** Capacities 500–1000 kg

All specifications subject to change without notice.

FM Approval

Intrinsically Safe: Class I, II, III; Div. 1 Groups A-G

Non-Incendive: Class I; Div. 2 Groups A-D